

2025

T1Nexus 800G SR8 Transceivers Test Report

UPDATED: JANUARY 2025

PREPARED BY: *Test Engineer BKO*



t1nexus.com



info@t1nexus.com



+1 877 816 3987



Introduction

Not all transceivers are created equally. How can you tell if one brand of transceiver is better than another? One of the most important performance parameters of high-speed transceivers is the Pre FEC (Forward Error Correction) Bit Error Rate (BER).

Executive Summary

A recent study conducted by BKO Corporate Research and Development evaluated T1Nexus transceivers based on manufacturer-reported specifications, IEEE 802.3df standards, and actual performance tests. Several MMF channels were assembled at the corporate research center of the third party, including 50 meters of worst-case OM4 MMF. The report focuses on the bit error ratio (BER) versus loss performance under temperature-controlled conditions, with channel loss emulated using variable optical attenuators. The study also includes tests on optical transmitted power, spectrum analysis, receiver sensitivity, and launch conditions, which are crucial for understanding performance variations.

The results for the 800G MMF transceivers (100G per lane) are summarized as follows:

- Using 50m of worst-case OM4 fiber, T1Nexus transceivers operate with 1.5 dB allocated for connector losses without impacting performance, maintaining wide headroom to accommodate temperature variations and aging.
- Power consumption of T1Nexus transceivers is like other 800G SR8 transceivers at 16.5 W (note that T1Nexus indicates 12W power consumption for this module on the datasheet).

The results of this study indicate that the evaluated T1Nexus transceivers support structured cabling with a 1.5 dB connector loss allocation, while still maintaining an ample additional margin of at least 1 dB after accounting for temperature and penalties. The study concludes that structured cabling, essential for deployment, maintenance, and scalability of AI networks, is effectively implemented using T1Nexus 800G SR8 transceivers or similar transceivers compatible with IEEE 802.3df specifications, provided connector losses are kept within the mentioned limits and cleanliness guidelines for connectivity are followed

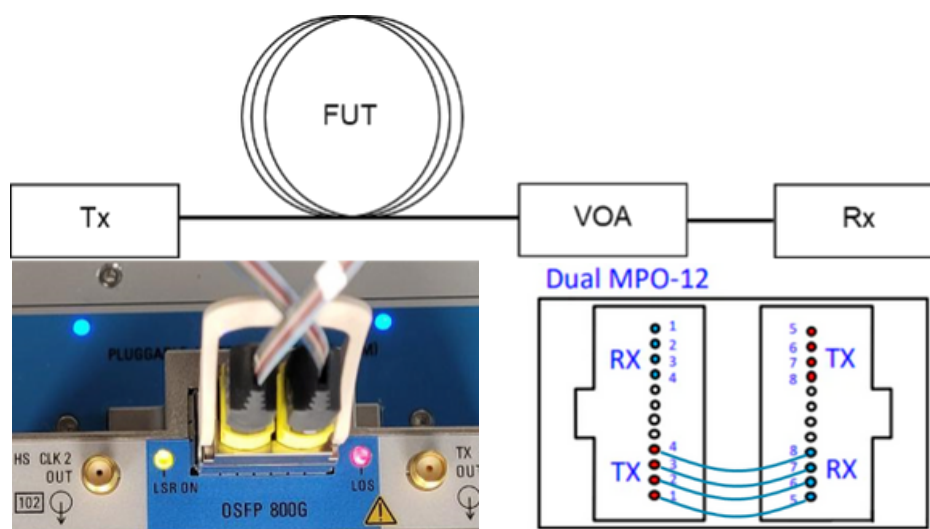

(TOP) General Test Setup for 800G dual MPO 12 module testing set-up. Four transmit lanes were connected in one MPO to four receive lanes in the other MPO and measured BER for half of the lanes for set-up simplicity. (BOTTOM) MPO connectors on the transceiver picture and detailed interconnection map

Main Performance Parameters

Pre-FEC BER measures errors in a data stream before any error correction is applied. While high speed transceivers like 400G and 800G must meet minimum specifications, those that only meet the standard requirement offer limited system margin and often suffer from poor link quality in real life applications.

Customer Feedback and Results

In numerous qualifications, customers have shared results with T1Nexus showing that our transceivers consistently outperform competitors, including original OEMs. Some brands barely meet the minimum standard requirement with limited margin in pre-FEC BER and show inconsistent performance, indicating variability in manufacturing processes. T1Nexus transceivers have demonstrated consistently better performance with pre-FEC BER < 1E-10 and typically in the order of 1E-12.

Why is This Important?

System design engineers and network operators strive for better system margins, enabling more tolerant system operations and accommodating wider variations in components and subsystems. For high-speed networks with 400Gbps and 800Gbps transceivers, poor link quality can lead to several operational issues impacting performance, reliability, and efficiency.

Common Issues with Poor Link Quality

- **Increased Error Rates:** Poor link quality leads to higher data transmission errors.
- **Packet Loss and Retransmissions:** Unpredictable packet drops increase network load and latency.
- **Reduced Data Throughput:** Signal degradation reduces overall throughput.
- **Decreased Network Stability:** Unstable optical links cause frequent disruptions.
- **Increased Maintenance Costs:** More frequent maintenance and troubleshooting are required.
- **Increased System Redundancy:** High degradation rates reduce system availability.

Impact on AI and Cloud Computing

Recent case studies show that poor link quality significantly impacts businesses using AI and cloud computing. In 2023, Dell 'Oro Group highlighted a Meta report revealing that up to 33% of AI processing time is lost due to network delays. T1Nexus transceivers would have significantly reduced wasted compute resource utilization and achieved a higher ROI.

Factors Affecting Link Quality

Achieving superior link quality involves:

- High-quality components
- Better design
- Precision tuning
- Consistent and automated manufacturing processes
- Better interface quality with connecting optical fibers
- Low loss MPO/MTP APC <0.35 dB connector

Contamination at connection points is a common cause of poor link quality. High-quality transceivers with low pre-FEC BER are more tolerant of minor imperfections. Not all components are equal, and the best components often have long lead times and higher costs. Inferior components and poor manufacturing processes lead to errors and lower BER.

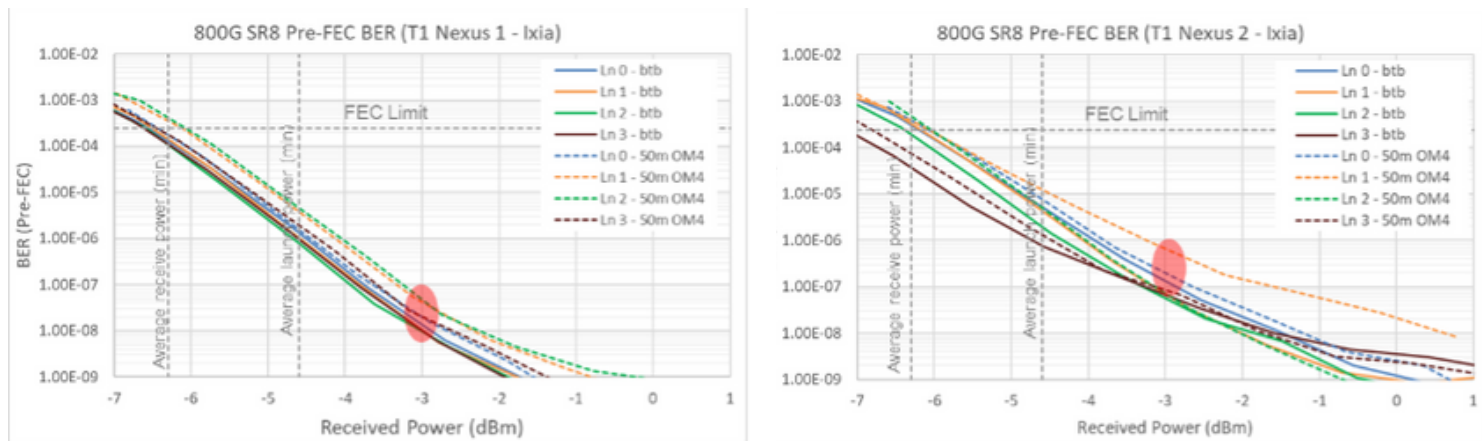

How T1Nexus Achieves Superior Performance

T1Nexus has the buying power to access the highest quality components and direct access to engineering resources from suppliers. Our manufacturing yield indicates our process control, ensuring only the highest quality components are shipped.

Conclusion

The results of this comprehensive study clearly indicate that T1Nexus transceivers offer superior performance, reliability, and efficiency compared to competitors. With a focus on high-quality components, precision tuning, and consistent manufacturing processes, T1Nexus ensures that their transceivers not only meet but exceed industry standards.

For system design engineers and network operators looking to enhance system margins, improve network stability, and reduce operational costs, T1Nexus provides an unparalleled solution. Our transceivers are designed to support the most demanding AI and cloud computing environments, significantly reducing wasted compute resources, and enhancing overall ROI.

To explore the complete research document and see how T1Nexus can transform your network infrastructure, please visit our website.

Contact T1Nexus for the complete research document.